



Evoko Room Manager

Take the hassle out of booking rooms.

Difficulty finding a free meeting room? The Evoko Room Manager solves this simply with the aid of small, elegant touch-sensitive screens that display the booking status of a meeting room clearly at the door. The complete system is based on Outlook, and this means that you don't have to learn any new software and that you can book a room from your own computer. The screen displays who has booked the room and for how long, and it is possible to make or cancel a booking directly on the screen. Extending an ongoing meeting is as simple as reaching out through the door! Green or red LED background illumination allows it to be seen at a distance whether the room is free or occupied, and the screen can suggest alternative rooms that are free. The system includes a "Report" function for reporting faults of the projector or other technical equipment in the meeting room, quickly and easily. The Evoko Room Manager is installed without any additional server or software on the company's Exchange server. Not even a plug-in in Outlook is needed. This means that the installation will not trespass on IT security. Furthermore, it makes the installation itself real easy.

Evoko Room Manager. Touch. Schedule. Meet.

EVOKO

INFO

- Easy to install.
 - No new server is required.
 - No additional software installation needed on the company's Microsoft Exchange server.
 - No new software installation on the users' computers and no heavy programming is needed.
 - Easy to use.
 - The complete system is based on Microsoft Outlook. No need to learn new software.
 - Book meetings in Microsoft Outlook or directly on touch screen.
 - Quickly find a free room just by looking around.
 - Book an instant meeting directly on the touch screen.
 - Extend an ongoing meeting directly on the touch screen.
 - End an ongoing meeting directly on the touch screen.
 - Find a free room directly on the touch screen.
 - Check equipment status to make sure that vital technical equipment for the meeting is working before entering the meeting room.
 - Report a problem connected to technical equipment in the meeting room.
- System requirements: MS Exchange server 2003/2007. Direct http/https access to MS Exchange server 2003 or 2007.
 - Display Size: 8 inches.
 - Touch Screen.
 - Ethernet Controller: 10/100 Mbit.
 - Device Input Power Sources: PoE – 48 V DC by RJ45. AC-DC Adapter 12 V DC by DC Jack.
 - PoE-PD Specification Version: IEEE 802.3-2005 (previously 802.3af).
 - PoE Maximum Power: 12.95 W.
 - USB: x1, Host, 1,5/12 Mbit, USB-A connector.
 - RJ45: x1, Ethernet 10/100 Mbit, PoE.
 - DC in: x1, 12 VDC.
 - LED Type (status light): Hyper Red, Super Green.
 - Complies with RoHS directive.
 - EMC: CE.
 - Electrical safety: CE.
 - AC/DC Adapter: CE-approved, 12 V DC output, 300 mm cable.
 - User interface languages: English, French, German, Spanish, Catalan, Galician, Basque, Portuguese, Italian and Russian.
 - Frame and main casing: Aluminum alloy.
 - Colour: White.
 - Size: 270 x 192 x 39 mm.
 - Weight: 1.3 kg.

ARTICLE NO: Evoko Room Manager ERM1001-series



Crystal clear. Green or red LED background illumination shows at a distance whether the meeting room is free or occupied. You can check the booking status with a few simple commands, and make or cancel your own bookings, or extend an ongoing meeting. The Evoko Room Manager is automatically synchronised with bookings made in Outlook.

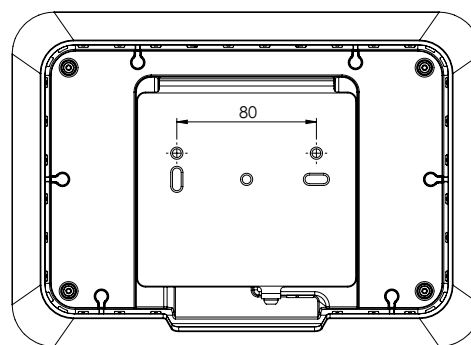
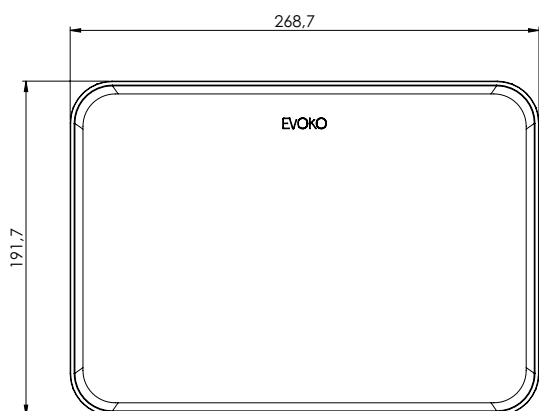

EVOKO